

The ruggedized CCM03 MK I design includes hinged covers with metal lock card detect switch option.

Features

- Available with 6 surface mount contacts, plus an optional blade switch to detect when the card is inserted and the cover is closed.
- The molding is polarized so that the cover can only be closed if the card is correctly inserted.

Construction

Contacts	Copper alloy
Plating	Contact area : Gold over nickel Terminals : Tin lead (2μ min)
Moldings	Thermoplastic UL 94V-0 rated
Slide lock	Stainless steel

Mechanical Data

Number of Contacts	6
Mechanical life	10,000 cycles min
Card insertion force	1 N max
Card extraction force	1 N max
Contact force	0.25 N min / 0.5 N max
Slide locking force	3.5 N max
Vibration	Frequency 10 to 500 Hz. Acceleration 50m/s ² Duration 6 hours - amplitude 0,35 mm Max electrical discontinuity 1μs
Shock	Peak value 500 m/s ² – Duration 11 ms 3 shocks in each direction of each axis Max electrical discontinuity 1 μs

Contact Electrical Data

Insulation resistance	1,000 MΩ min
Resistance	100 mΩ max
Current rating	10 μA min / 1 A max
Dielectric strength	750 Vrms min

Switch Electrical Data

Card detection switch	Normally open (closes when card inserted and cover is shut)
Contact resistance	100 mΩ max
Dielectric strength	250 Vrms min
Current rating	1 mA min / 10 mA max
Maximum power	0.2 VA

Environmental Data

Operating temperature	-40°C to +85°C
Soldering temperature	Temperature/time profile acc. to CECC00802 para. 6.1 Fig. 3 with peak temperature 250°C
Damp heat	IEC 512 test number 11c (10 days)
Salt mist	IEC 512 test number 11f (96 hours)

Ordering Code

Part Number	Switch	Quantity per Reel
CCM03-0-1	No	750
CCM03-0N0-1	Yes	750

Packaging

5 reels per box.

CCM03 MK I

Dimensional Drawings

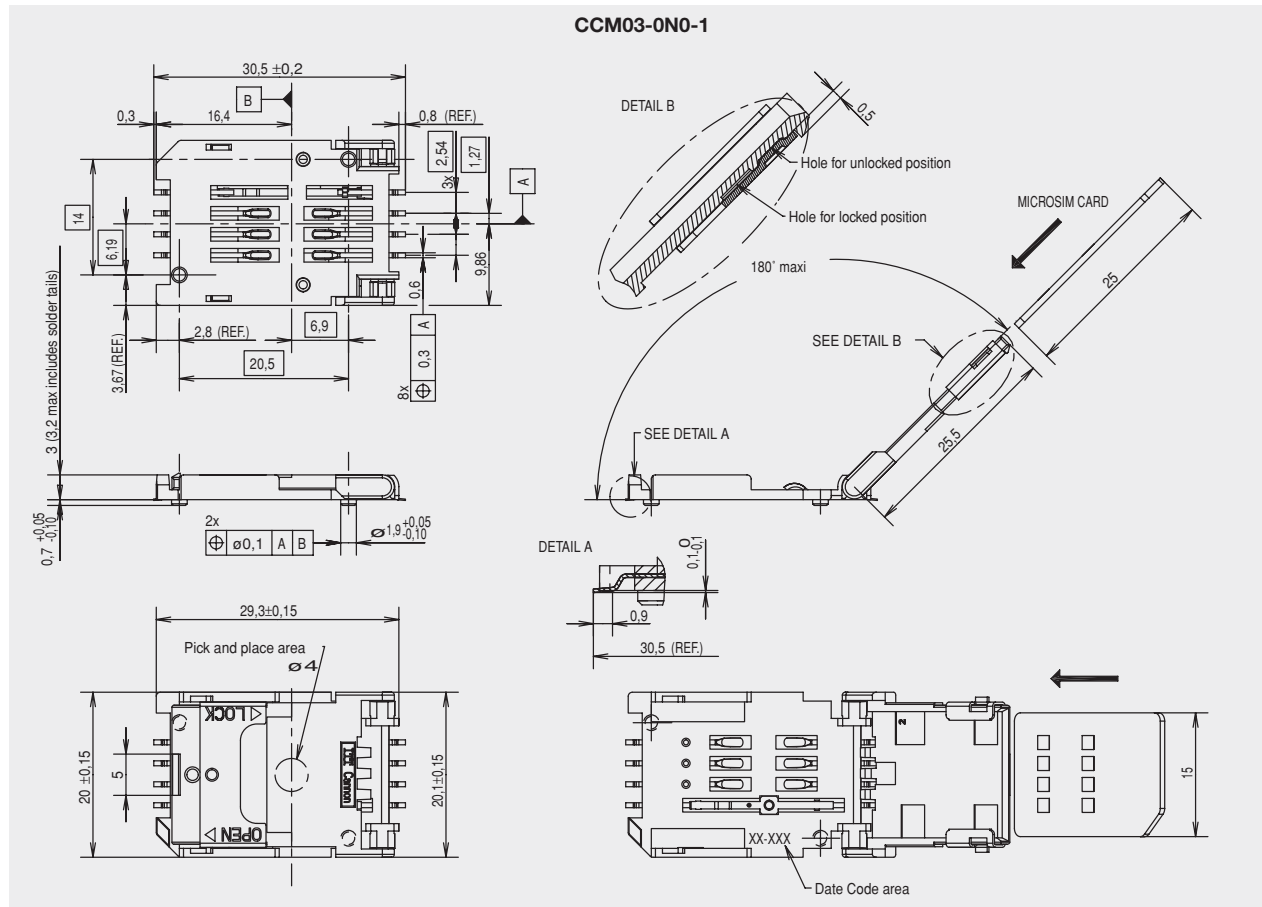

PCB Layout

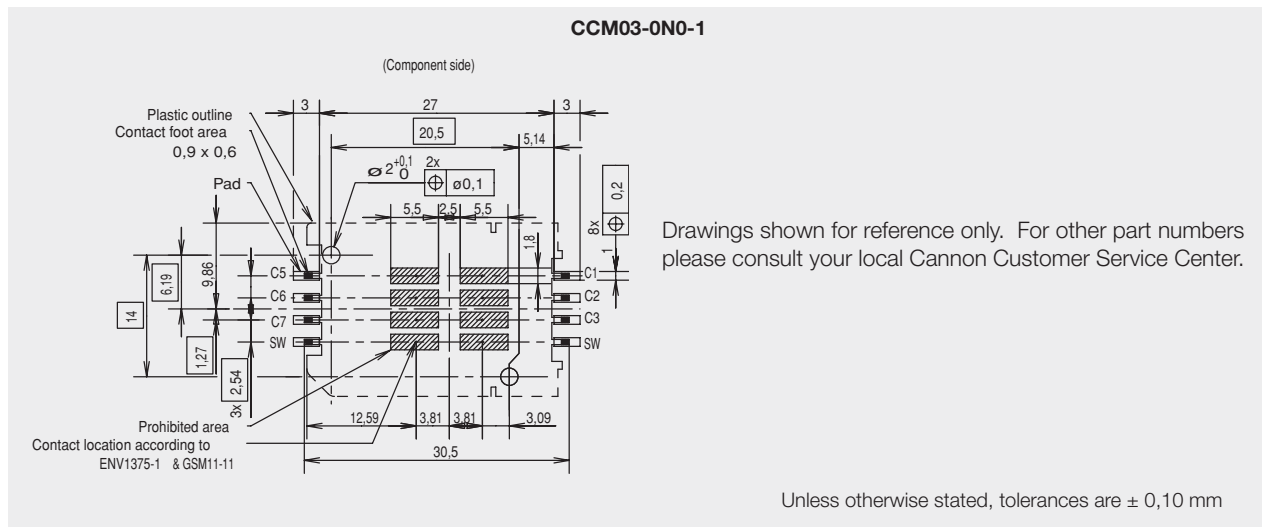



A new range of CCM03 connectors have been developed to interface with SIM/SAM cards as defined by GSM11-11 and ENV1375-1. The connectors are available with either hinged covers or fixed covers and have been designed to minimize the amount of space needed for PCB mounting.

Features

Hinged Cover

- Available with 6 or 8 contacts, with or without PCB locating pegs.
- Available with insulated card presence switch.
- The cover springs open when unlocked while the card is in place.
- The molding is polarized so that the cover can only be closed if the card is correctly inserted.
- The cover can be replaced without removing the connector from the PCB.
- Inspection slots allow an electrical test to be made without opening the cover.
- The overall height of the connector is only 2,5 mm. The amount of space needed to mount the connector is just 29,65 mm x 17,2 mm.

Fixed Cover

- Available with 6 or 8 contacts.
- The overall height of the connector is 2,85 mm max. Only 25,5 mm x 17,2 mm of board space is required to mount the connector.

General

- With tape and reel packaging as standard, the connectors are designed to be automatically pick-and-placed.
- The high temperature thermoplastic moldings are suited for infrared and convection soldering processes.
- By using an inlay finish in the contact area the life of the precious metal is extended by over 10 times that of standard gold plating.
- Robustly formed printed circuit tails allow a co-planarity of $\pm 0,05$ mm to be maintained.

Construction	
Contacts	Copper alloy
Plating	Contact area : Gold alloy inlay or gold over nickel Terminals : Tin lead (2 μ min)
Moldings	High temp. thermoplastic UL 94V-0 rated
Slide lock/metal cover	Stainless steel

Mechanical Data	
Number of Contacts	6 or 8
Mechanical life, hinged cover	10,000 cycles min
Mechanical life, fixed cover	50,000 cycles
Card insertion force	Hinged cover: 1 N max Fixed cover: 3 N max
Card extraction force	Hinged cover: 1 N max Fixed cover: 0.80 N min / 3 N max
Contact force	0.25 N min / 0.50 N max
Slide locking force	2 N min / 6 N max
Vibration	Frequency 10 to 500 Hz. Acceleration 50m/s ² Duration 6 hours - amplitude 0,35 mm Max electrical discontinuity 1 μ s
Shock	Peak value 500 m/s ² – Duration 11 ms 3 shocks in each direction of each axis Max electrical discontinuity 1 μ s

Contact Electrical Data	
Insulation resistance	1,000 M Ω min
Resistance	100 m Ω max
Current rating	10 μ A min / 1 A max
Dielectric strength	750 Vrms min

Switch Electrical Data	
Card detection switch	Normally open
Contact resistance	100 m Ω max
Dielectric strength	250 Vrms min
Current rating	1 mA min / 10mA max
Maximum power	0.2 VA

Environmental Data	
Operating temperature	-40°C to +85°C
Soldering temperature	Temperature/time profile acc. to CECC00802 para. 6.1, Fig. 3 with peak temperature 250°C
Damp heat	IEC 512 test number 11c (10 days)
Salt mist	IEC 512 test number 11f (96 hours)

Packaging	
Quantity per reel, see table next page.	

CCM03 MK II

Ordering Code

Part Number	Number of Contacts	Cover	PCB Locating Pegs	Quantity per reel	Contact Finish	Switch lock	Card Presence switch
CCM03-3001 R102	6	Hinged	No	1000	Inlay	No	No
CCM03-3002 R102	6	Hinged	Yes	1000	Inlay	No	No
CCM03-3003 R102	8	Hinged	No	1000	Inlay	No	No
CCM03-3004 R102	8	Hinged	Yes	1000	Inlay	No	No
CCM03-3009 R102	6	Hinged	No	1000	Gold	No	No
CCM03-3010 R102	6	Hinged	Yes	1000	Gold	No	No
CCM03-3011 R102	8	Hinged	No	1000	Gold	No	No
CCM03-3012 R102	8	Hinged	Yes	1000	Gold	No	No
CCM03-3013 R102	6	Hinged	No	1000	Gold	No	Yes (insulated)
CCM03-3514 R122	6	Hinged	No	1200	Inlay	Yes	No
CCM03-3504 R122	8	Fixed	No	1200	Inlay	No	No
CCM03-3505 R122	6	Fixed	No	1200	Inlay	No	No



Dimensional Drawings

Hinged Cover CCM03 - 3001 (6 contacts)

3002 (6 contacts - PCB locating pegs)

3003 (8 contacts)

3004 (8 contacts - PCB locating pegs)

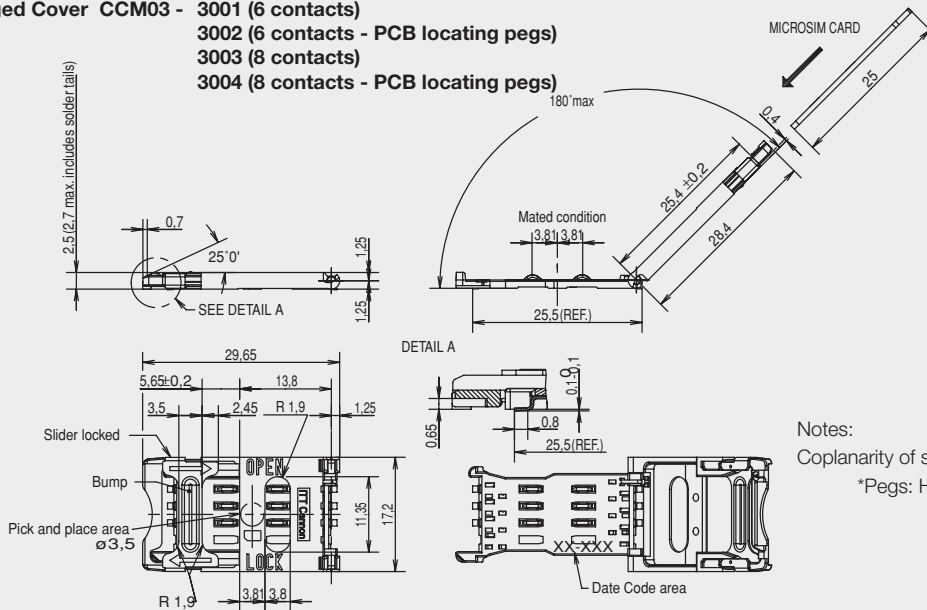

PCB Layout

CCM03-3001 / 3002

(Component side)

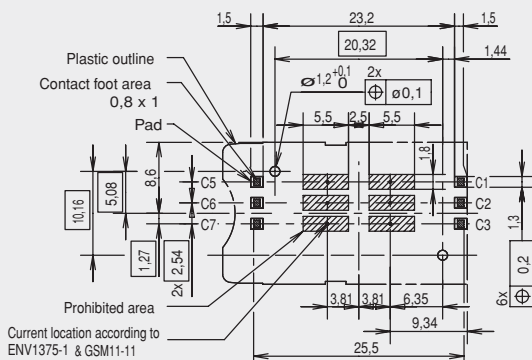

CCM03-3003 / 3004

(Component side)

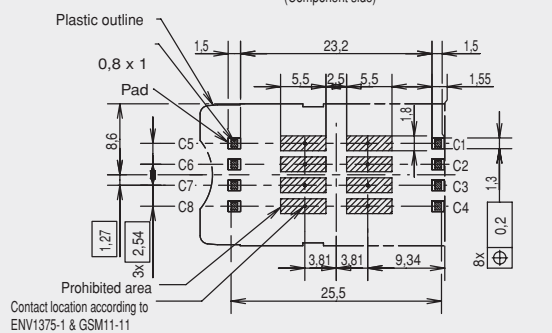

Unless otherwise stated, tolerances are $\pm 0,10$ mm

CCM03 MK II Hinged Cover



Insulated Card Presence Switch

Dimensional Drawings

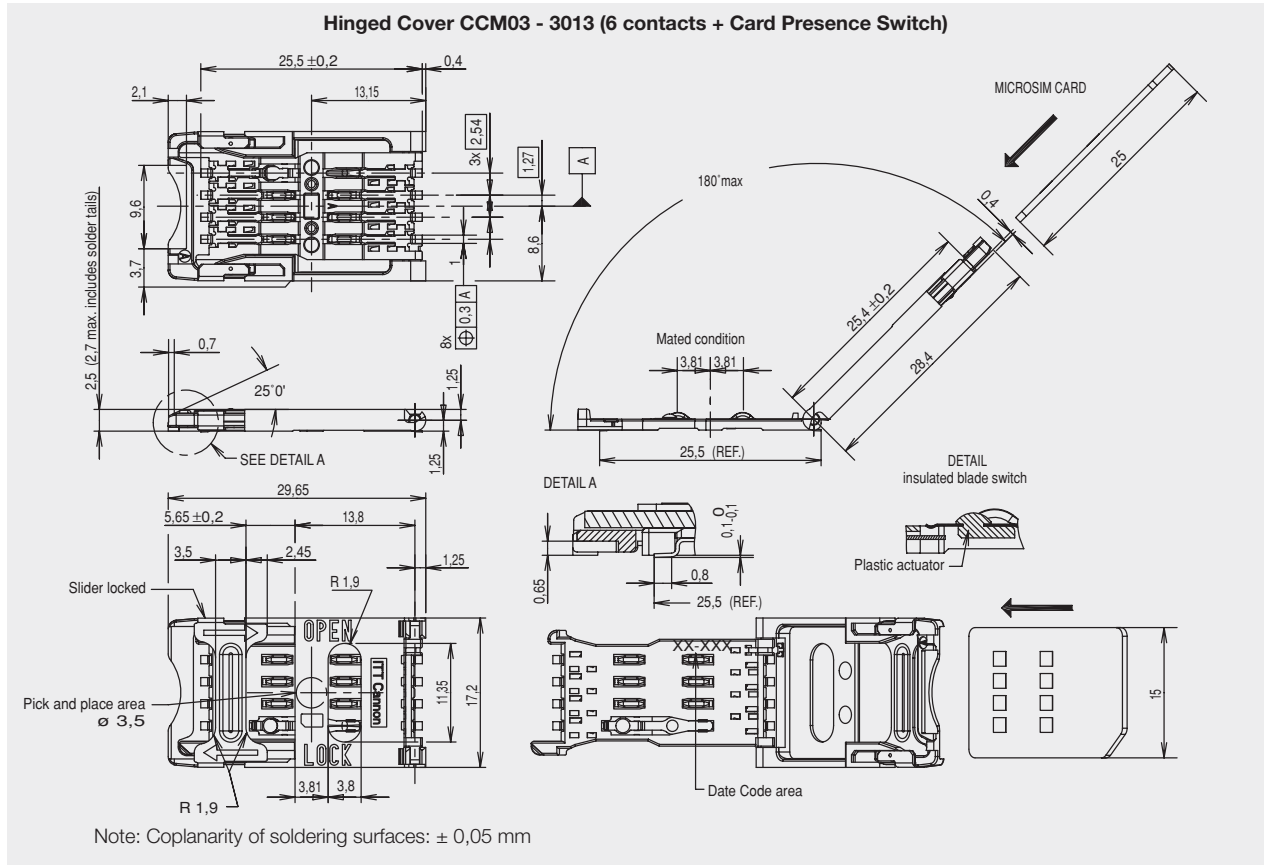

PCB Layout

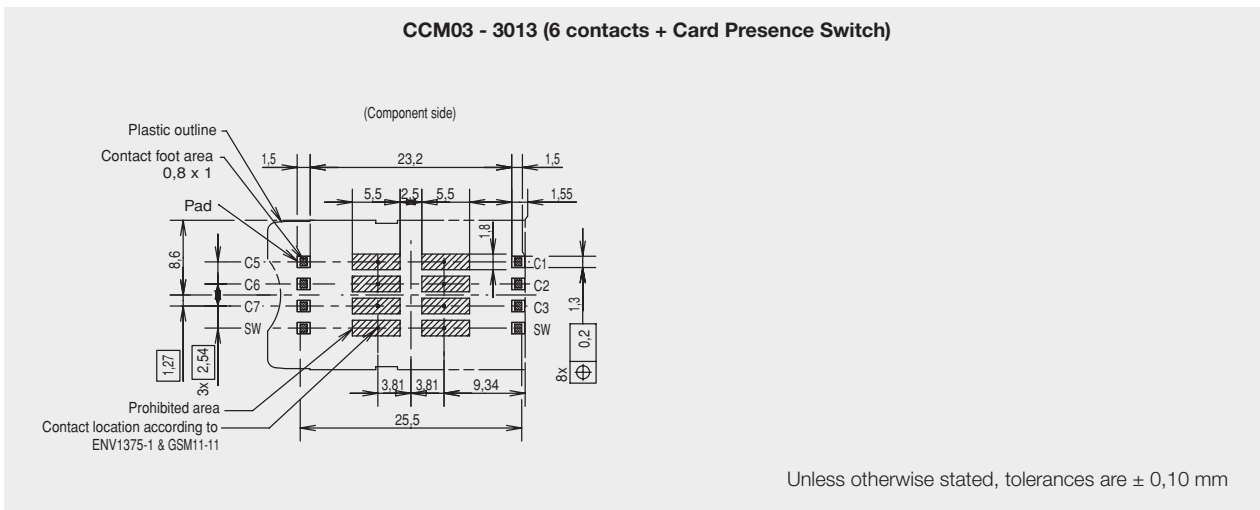

CCM03 MK II Hinged Cover

Dimensional Drawings

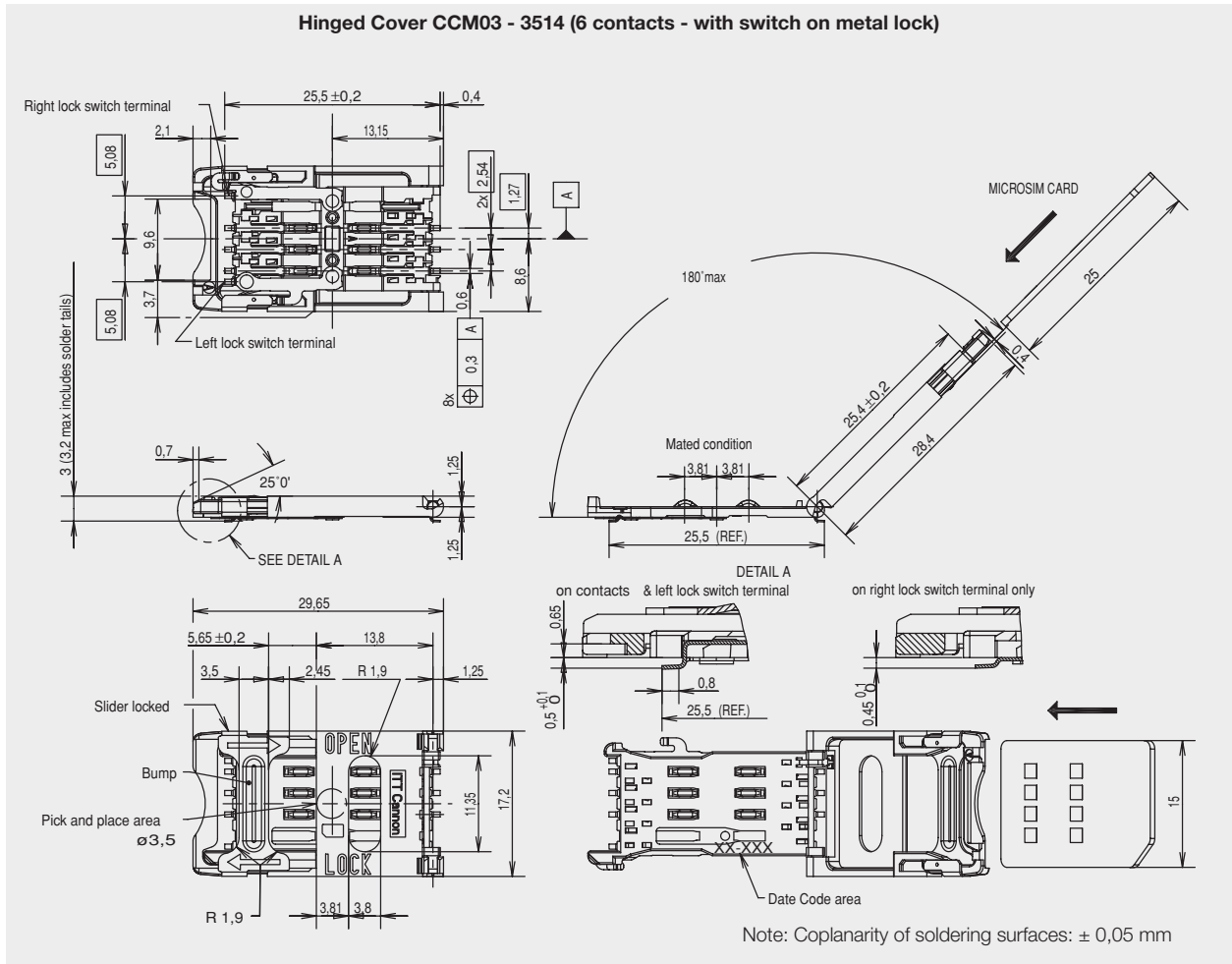

PCB Layout

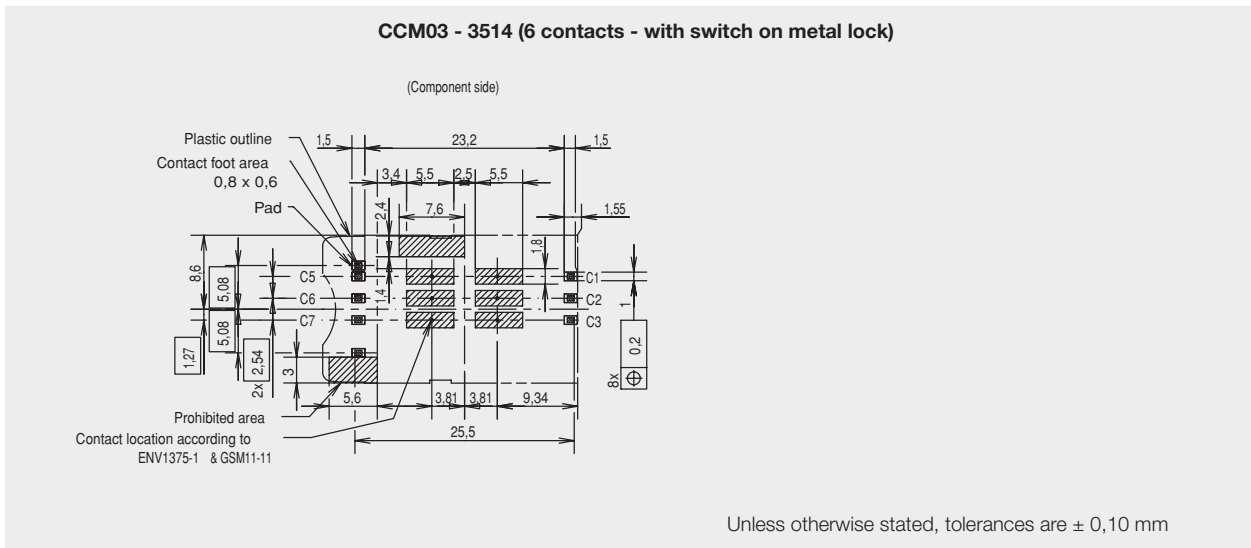

CCM03 MK II Fixed Cover

Dimensional Drawings

Fixed cover CCM03 - 3504 (8 contacts)

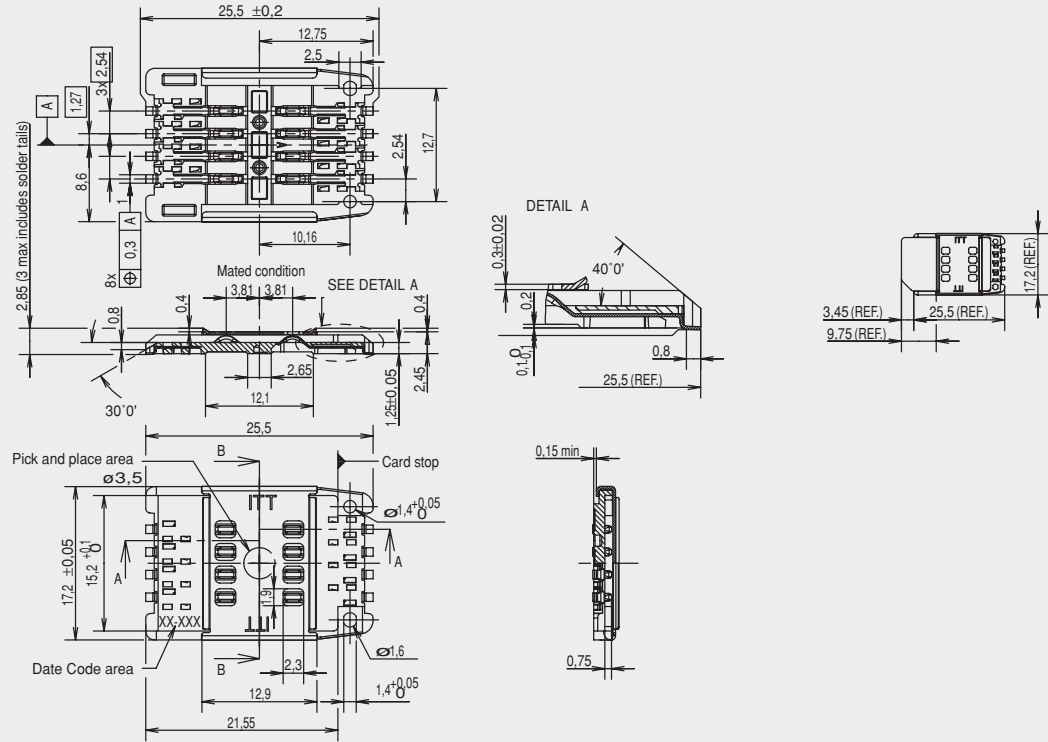

Note: Coplanarity of soldering surfaces: $\pm 0,05$ mm

PCB Layout

CCM03 - 3505

(Component side)

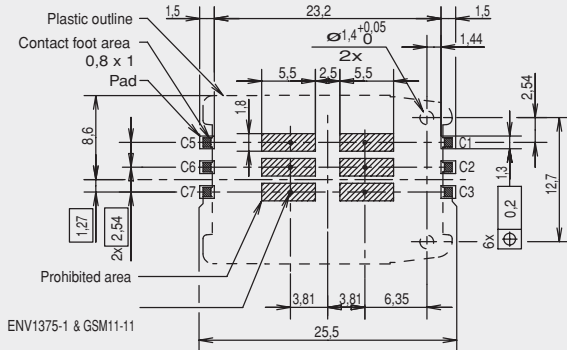

CCM03 - 3504

(Component side)

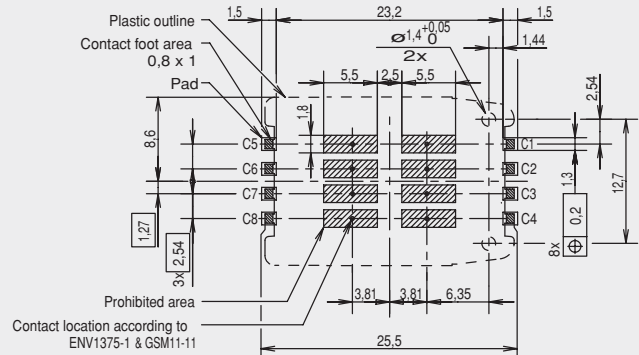

Unless otherwise stated, tolerances are $\pm 0,10$ mm

CCM03 MK II with Auto Lock cover



A new range of CCM03 connectors have been developed to interface with SIM/SAM cards as defined by GSM11-11 and ENV1375-1. The connectors are available with a hinged metallic cover and have been designed to provide an easier open/lock function and side card entry.

Features

- Available with 6 cross contacts which are designed to give a consistently reliable normal force over the life of the connector.
- The hinged metallic cover can automatically lock by pressure.
- Side entry of the card ensures easier positioning of the card into the connector.
- Insulated blade switch version available for detection card when cover is closed.
- The molding is polarized so that the cover can only be closed if the card is correctly inserted.
- Inspection slots allow an electrical test to be made without opening the cover.
- With tape and reel packaging as standard, the connectors are designed to be automatically pick-and-place.
- The moldings are made from high-temperature thermoplastics suited to infrared and convection soldering processes.
- Robustly formed printed circuit tails allow a coplanarity of $\pm 0,05$ mm to be maintained.

Construction

Contacts	Copper alloy
Contacts finish	Gold over nickel
PC tail plating	Tin lead (2 μ min)
Molding	High temp. thermoplastic, UL94V-0
Cover	Stainless steel

Mechanical Data

Number of Contacts	6
Mechanical life	10,000 cycles min
Contact force	0.35 N min / 0.50 N max
Vibration	Frequency 10 to 500 Hz. Acceleration 50m/s ² Duration 6 hours - amplitude 0.35 mm (0.014) Max electrical discontinuity 1 μ s

Contact Electrical Data

Insulation resistance	1,000 M Ω min
Resistance	100 m Ω max
Current rating	10 μ A min / 1 A max
Dielectric strength	750 Vrms min

Switch Electrical Data

Card detection switch	Normally open
Contact resistance	100 m Ω max
Dielectric strength	250 Vrms min
Current rating	1mA min / 10m A max
Maximum power	0.2 VA

Environmental Data

Operating temperature	-40°C to +85°C
Soldering temperature	Temperature/time profile acc. to CECC00802 para. 6.1, Fig. 3 with peak temperature 250°C
Damp heat	IEC 512 test number 11c (10 days)
Salt mist	IEC 512 test number 11f (96 hours)

Ordering Code

Part Number	Number of Contacts	Cover	Card Presence Switch	Quantity per reel
CCM03-3517	6	Side Hinged	No	1300
CCM03-3518	6	Front Hinged	Yes (insulated)	1300
CCM03-3529	6	Front Hinged	No	1300

Packaging

5 reels per box.

CCM03 MK II with Auto Lock cover

Dimensional Drawings

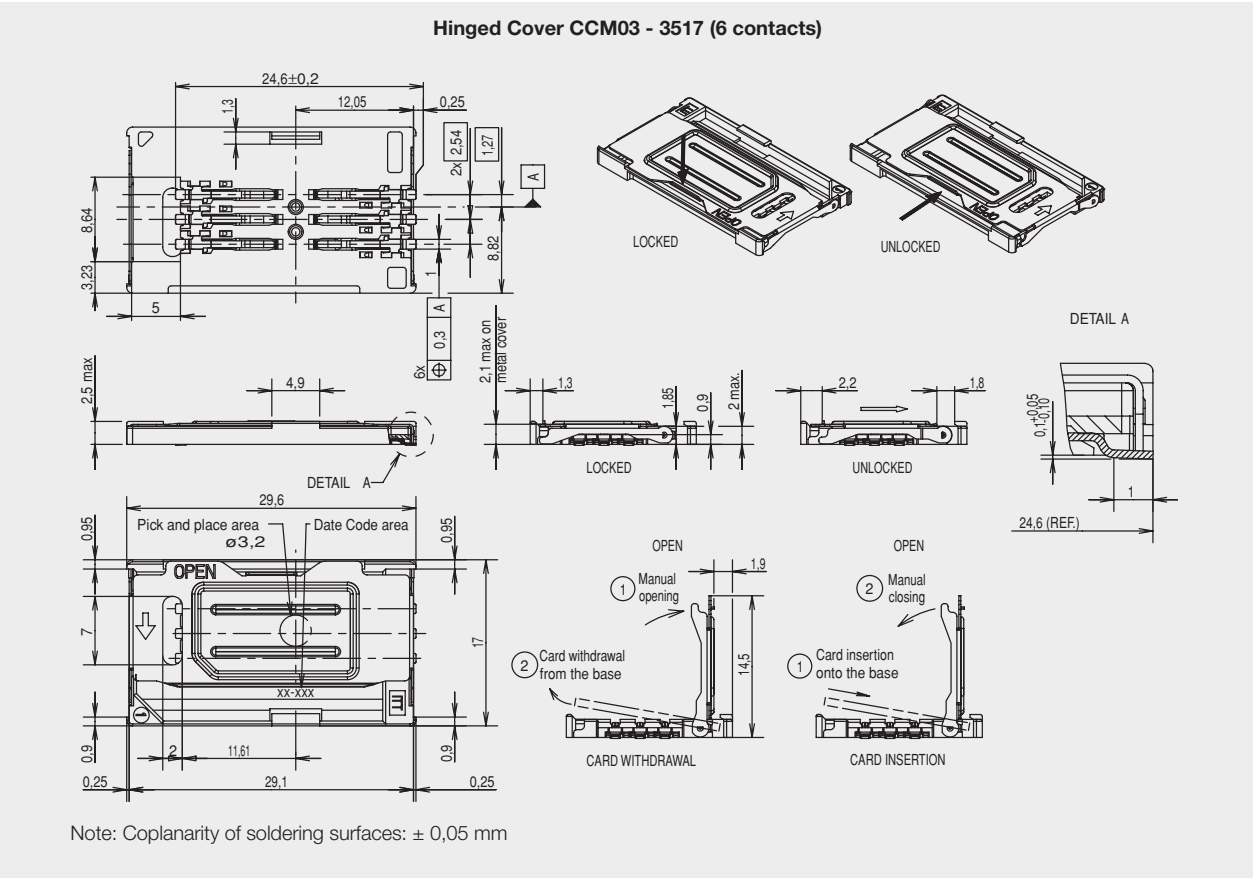

PCB Layout

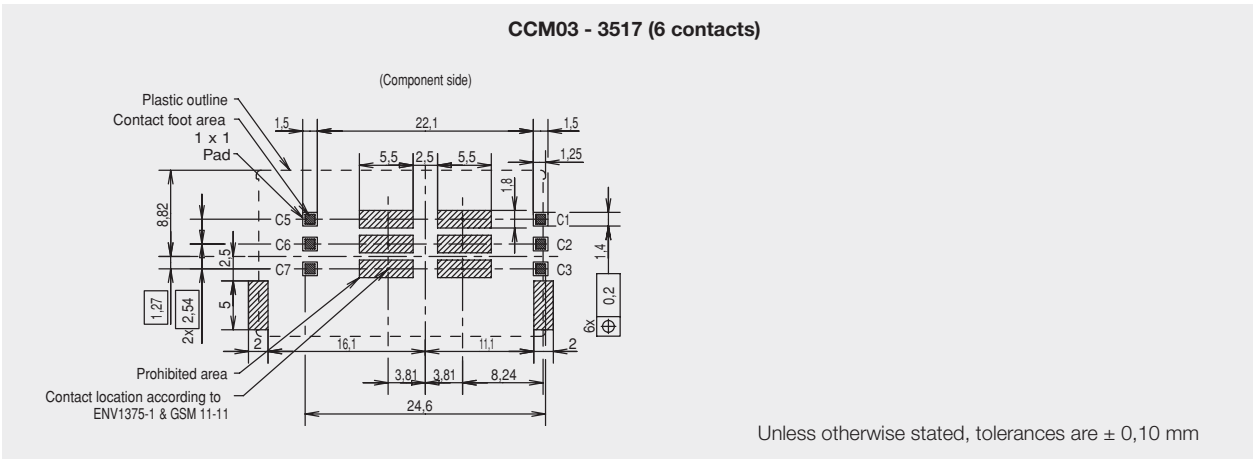

CCM03 MK II with Auto Lock cover

Dimensional Drawings

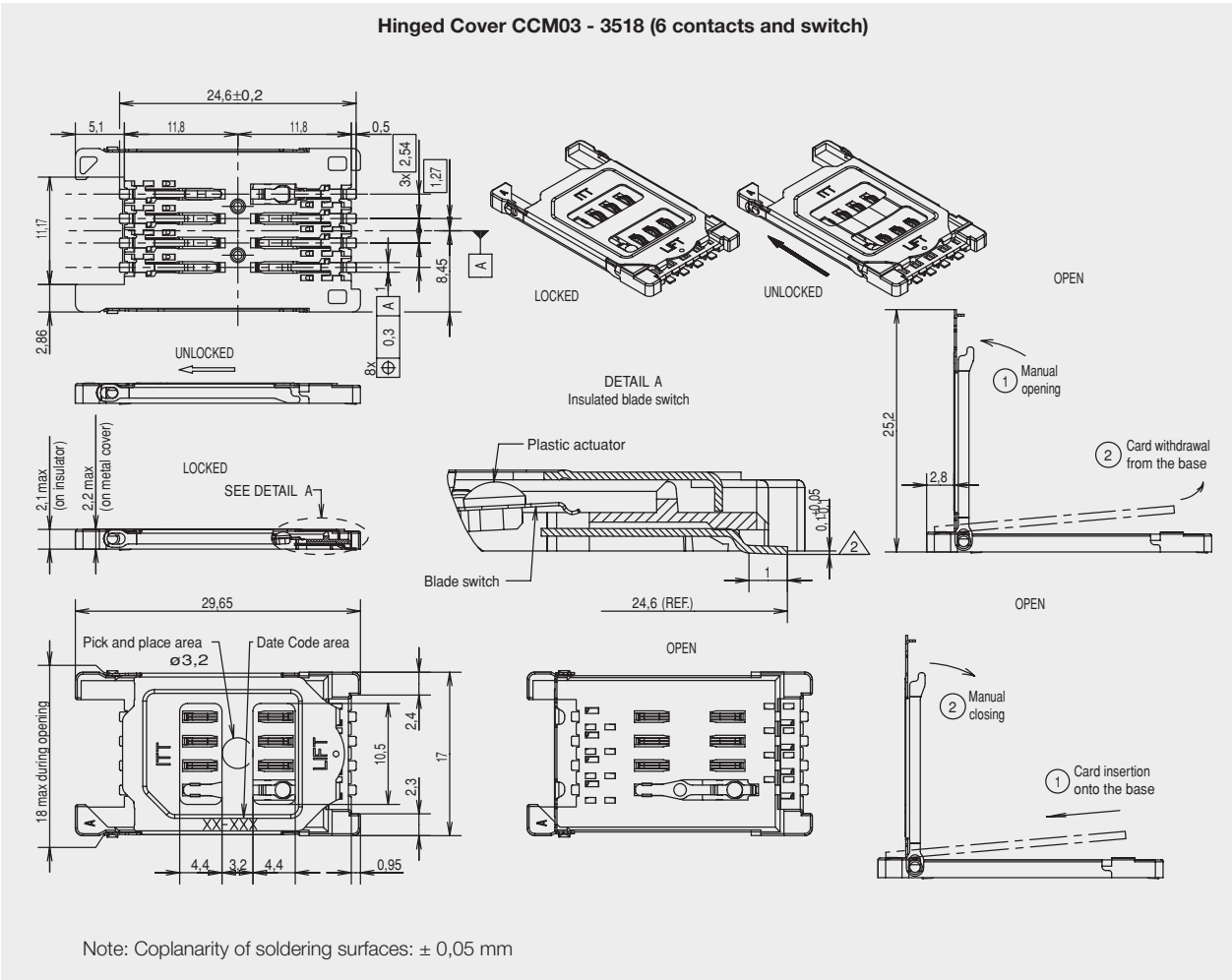

PCB Layout

CCM03 - 3518 (6 contacts and switch)
CCM03-3529 (without switch) layout is similar except SW pads

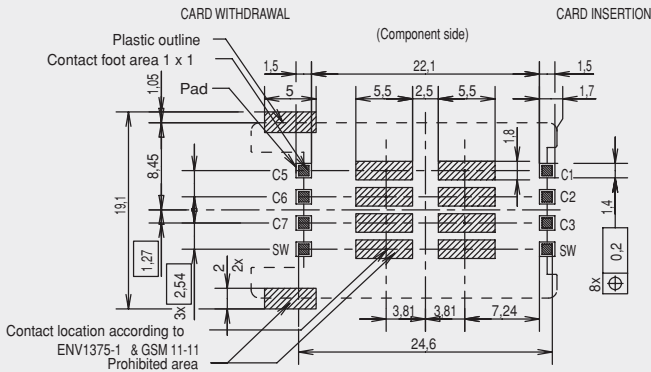

Unless otherwise stated, tolerances are $\pm 0,10$ mm